

DRWG# 1827

Date: 7.28.09

WWW.ACOUSA.COM

QuARTz By ACO INSTALLATION DRAWING

Shower Channel Concrete Slab Installation

ACO Polymer Products Inc.



825 W. Beechcraft St.
P.O. Box 12067
Casa Grande, AZ 85122
PH: 520-421-9988
FX: 520-421-9899

12080 Ravenna Road
P.O. Box 245
Chardon, OH 44024
PH: 440-285-7000
FX: 440-285-8517

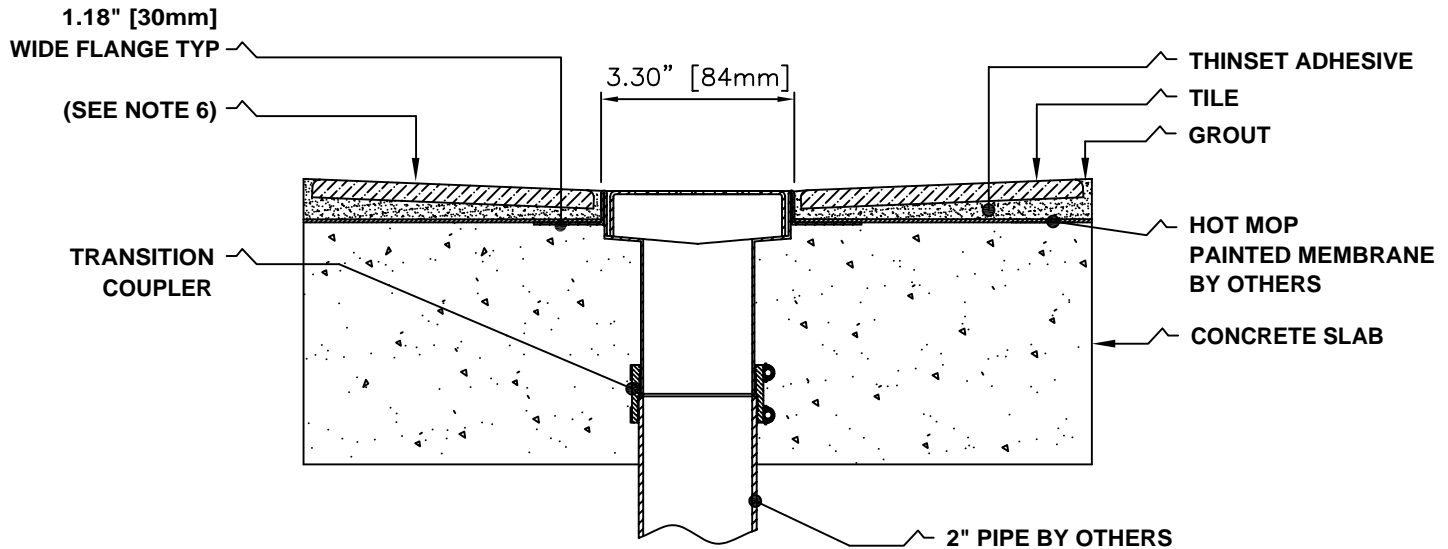

NOTES:

1. Applicable detail for floor slab and elevated slab.
2. Concrete slab structure should be sufficient strength to take weight of finished shower base.
3. Shower channel trench envelope should be "blocked out" during concrete slab pour to allow the shower channel to be installed separately from the main structural floor slab.
4. Pipe stub should be fully accessible to allow transition coupler to be installed prior to finished concrete pour around shower channel body.
5. Refer to hot mop painted membrane manufacturers regarding membrane application and properties.
6. Finished shower floor should slope a minimum of 1% (1/8" per 1ft) to the shower channel.
7. Refer to ACO'S latest installation instructions for complete details.

DRWG# 1827

Date: 7.28.09

WWW.ACOUSA.COM

QuARTz By ACO SPECIFICATION CLAUSE

Shower Channel Concrete Slab Installation

ACO Polymer Products Inc.



825 W. Beechcraft St.
P.O. Box 12067
Casa Grande, AZ 85122
PH: 520-421-9988
FX: 520-421-9899

12080 Ravenna Road
P.O. Box 245
Chardon, OH 44024
PH: 440-285-7000
FX: 440-285-8517

The QuARTz by ACO shower channel and grate system shall be stainless steel grade 304 manufactured by ACO Polymer Products, Inc. USA
The surface finish shall be *__(choose one)_____

Shower channels shall be 3-5/16" [84mm] wide, with length as specified on Architects plans / Architects specification.
Outlet spigot (O.D.) diameter shall be 50mm [1.968"]

Transition coupler shall be supplied by ACO, or equal UPC certified equivalent.

ACO recommends checking local plumbing codes prior to installation.

The system shall be installed in accordance with the manufacturer's instructions and recommendations.

* Electropolished OR Oil Rubbed Bronze